

AS19

Quick Start Guide

Schnellanleitung | Guide de démarrage rapide
 | Guida Rapida all'uso | Guía de inicio rápido |
 クイックスタートガイド



User Manual, FAQs



Box Contents

Lieferumfang | Contenu de la boîte | Contenuto della
 confezione | Contenido de la caja | ボックスの内容



Headphones



Charging Dock

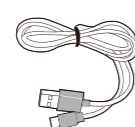

Power Cable for
 Charging Dock

Product Overview

Produktübersicht | Vue d'ensemble du produit | Panorámica
 Prodotto | Descripción general del producto | 製品概要

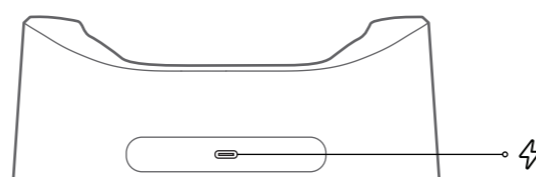
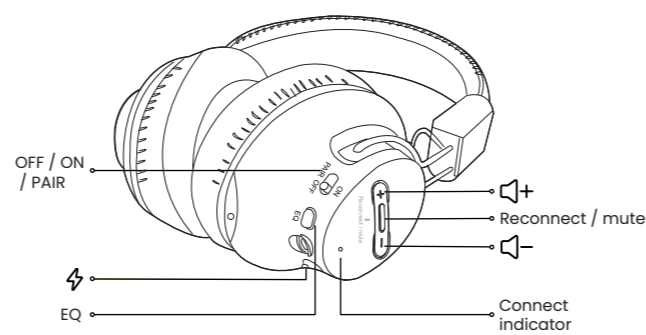

Charging

Aufladen | Charge | Ricarica | Cargat | 充電

OPTION 1

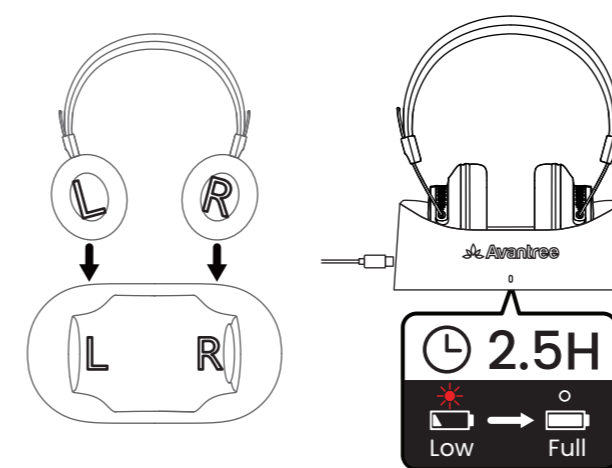

OPTION 2

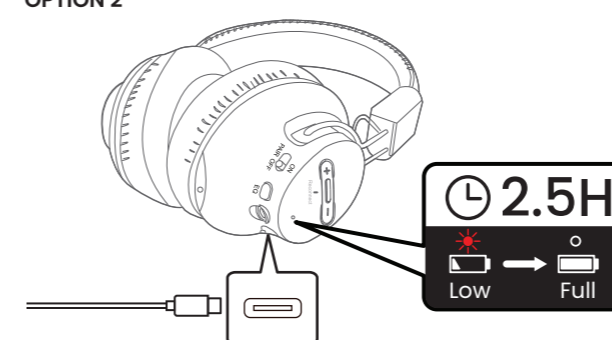

How to connect

Wie man verbindet | Comment se connecter |
 Come connettersi | Cómo conectar |
 どうやって接続する

1 Use with Phone

Verwendung mit Telefon | Utilisation avec téléphone | Utilizzare con
 telefono | Usar con teléfono | 電話で使用する

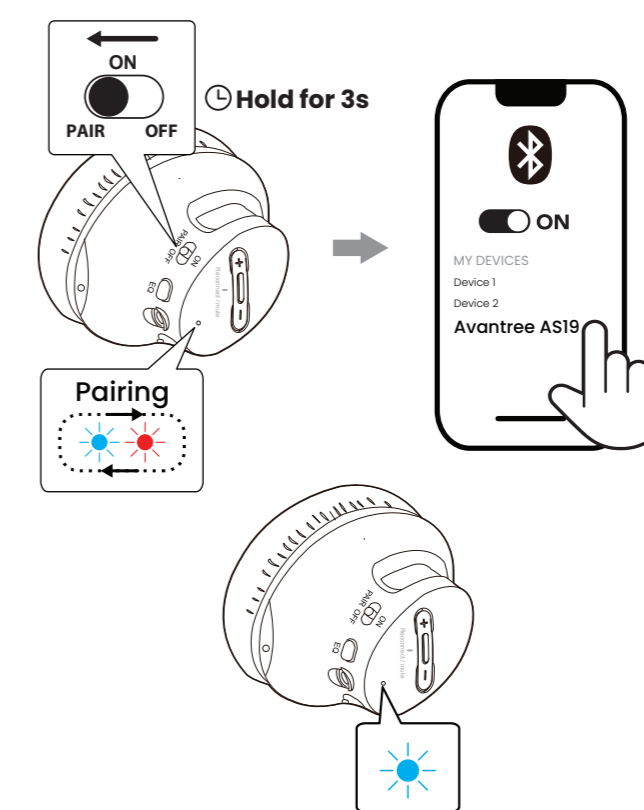

2 Use with Smart TV

Verwendung mit Smart-TV | Utilisation avec Smart TV | Utilizzare con
 Smart TV | Usar con Smart TV | スマートテレビで使用する

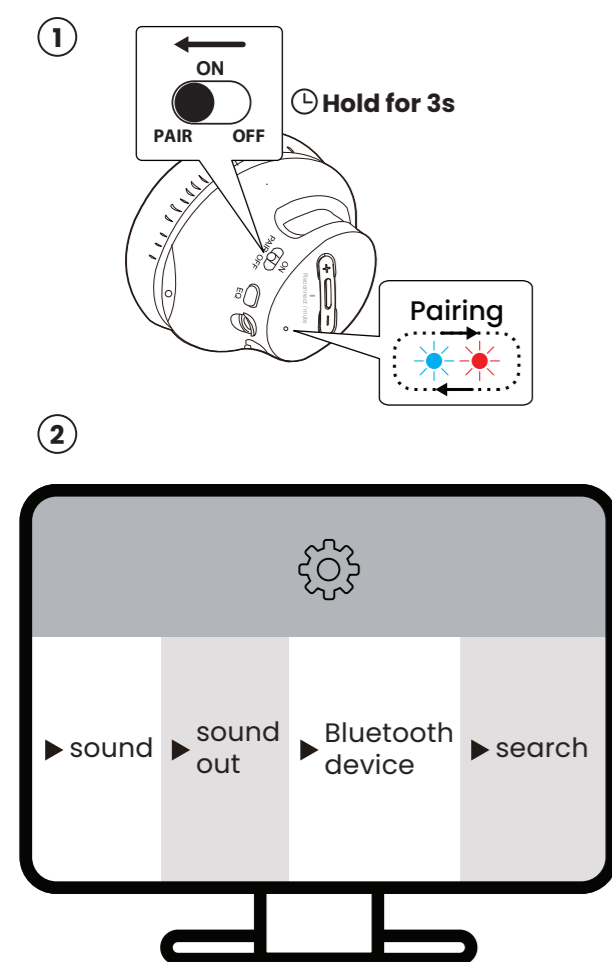

3

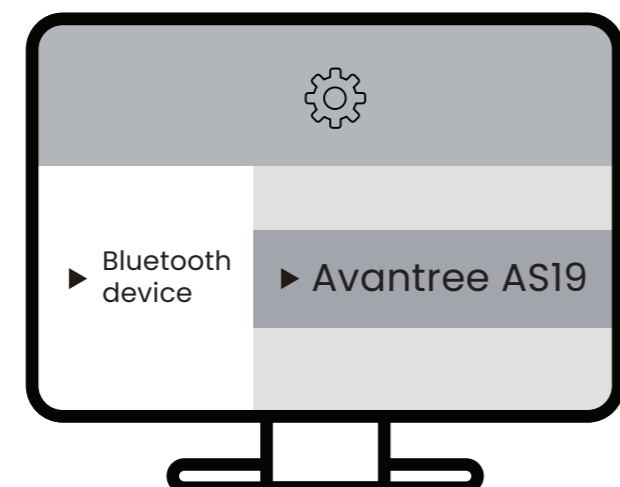

4

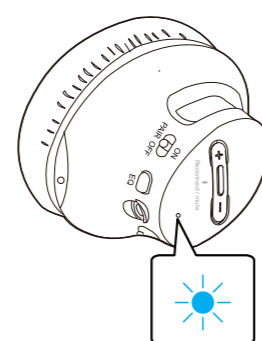

3 Adjusting the Volume

Die Lautstärke anpassen | Ajuster le volume | Regolare il volume |
 Ajustar el volume | ボリュームを調整する

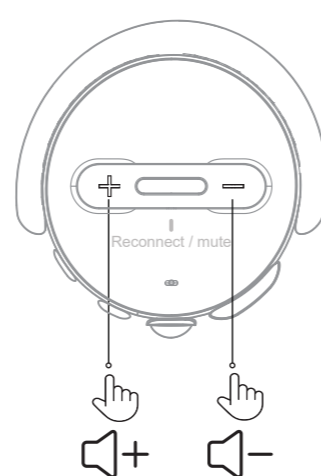

Contact Us

Kontaktieren Sie uns | Contactez-nous |
 Contattaci | Contáctenos | お問い合わせ

avantree.com/submit-a-ticket

support@avantree.com

US	+1 800 232 2078	9am-5pm PST	Mon-Fri
CA	+1 800 232 2078	9am-5pm PST	Mon-Fri
UK	+44 208 068 2023	9am-6pm GMT	Mon-Fri
DE	+49 322 2109 7297	10am-5pm CET	Mon-Fri
FR	+33 17 634 0312	10am-5pm CET	Mon-Fri
IT	+39 069 4803 330	10am-5pm CET	Mon-Fri
ES	+34 93 1786 261	10am-5pm CET	Mon-Fri
AU	+61 2 8310 9897	11am-7pm AEST	Mon-Fri

avantree.com/support/as19

Scan QR code on the product to register
 for 24-month warranty.



EU Importer and Responsible Person:
 Avantree Europe Z O.O.
 Ul. Żoinierzy i Dywizji Wojska
 Polskiego 78a/2 84-230 Rumia,
 Pomorskie, Poland
 +48 22 307 25 37
 support-eu@avantree.com

US Importer:
 Avantree Corporation
 San Jose, California 95119 USA
 +1 800 232 2078
 support@avantree.com

Manufacturer:
 Avantronics Limited
 Luohu District, Shenzhen
 518000 China
 +86 755 8228 5022
 support@avantronics.com

UK Importer:
 Avantree Limited
 Watford, WD18 0HQ UK
 +44 20 8068 2023
 support-uk@avantree.com

Battery Manufacturer and Responsible Person:
 Shenzhen Keruliong Technology Co., Ltd.
 Building 3-2, Fudigang Second Industrial Zone,
 Pingdong, Pingdi Street, Longgang, Shenzhen, China
 +86 137 1380 2030 3354641970@qq.com



Item No.: BTHS-AS19
 Model No.: BTHS-AS9S ; WSCG-19
 FCC ID: WJ5-BTHS-AS9S ; WJ5-WSCG-19
 IC: 8475A-AS9S ; 8475A-WSCG19
 Made in China

Z-PRG0-AS19-V1