

# Table of Contents

<b>BOX CONTENTS</b> .....	<b>2</b>
<b>PRODUCT INTRODUCTION (HEADPHONES)</b> .....	<b>3</b>
PRODUCT OVERVIEW .....	3
BUTTON FUNCTIONS .....	3
LED INDICATORS .....	4
<b>PRODUCT INTRODUCTION (TRANSMITTER)</b> .....	<b>5</b>
PRODUCT OVERVIEW .....	5
BUTTON FUNCTIONS .....	6
LED INDICATORS .....	6
<b>SETTING UP</b> .....	<b>7</b>
CONNECTING TO YOUR TV.....	7
<i>Option 1 - Optical port (recommended)</i> .....	7
<i>Option 2 - AUX 3.5mm port</i> .....	8
<i>Option 3 - RCA port</i> .....	8
CONNECTING THE HEADPHONES TO THE TRANSMITTER.....	9
SETTING UP YOUR TV (FOR OPTICAL CONNECTIONS ONLY).....	10
<b>CHARGING THE HEADPHONES</b> .....	<b>11</b>
<b>ADVANCED FEATURES</b> .....	<b>12</b>
USING THE HEADPHONES WITH YOUR PHONE/TABLET .....	12
<b>FACTORY RESET</b> .....	<b>13</b>
<b>SPECIFICATIONS</b> .....	<b>14</b>
<b>FAQ</b> .....	<b>15</b>
<b>CONTACT US</b> .....	<b>16</b>

# Box Contents

A



Headphones X 2

B



Transmitter

C



Dual headphones stand

D

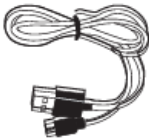

Power cable for transmitter

E

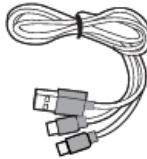

Power cable for headphones

F

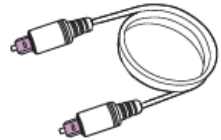

Optical audio cable

G

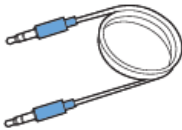

AUX 3.5mm Audio Cable

H





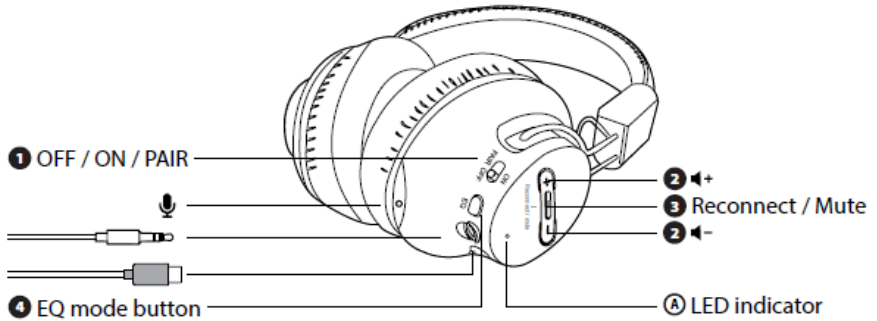

3M tape for transmitter

# Product Introduction (Headphones)

## Product Overview



## Button Functions

No.	Button	Function
<b>1</b>		Switch to "ON / OFF" position to turn the headphones on / off
		Hold in "PAIR" position for 3 seconds to enter pairing mode
<b>2</b>		Press or hold to adjust volume
		Press & hold both buttons for 10 seconds to clear pairing history
<b>3</b>		Press once/twice to mute/unmute the headphones
		If headphones fail to auto-connect to transmitter, press once to activate reconnection
<b>4</b>		Press once to switch between balanced and clear voice modes

## LED Indicators



No.	Status	LED Indicator
	Power ON	Flashing blue
	Power OFF	Off
	Pairing	Flashing red & blue
	Connected	Solid blue
	Low battery	Flashing red
	Charging	Solid red
	Charging complete	Off

## Product Introduction (Transmitter)

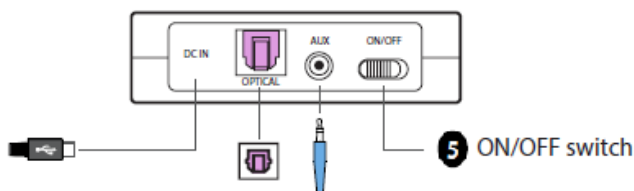
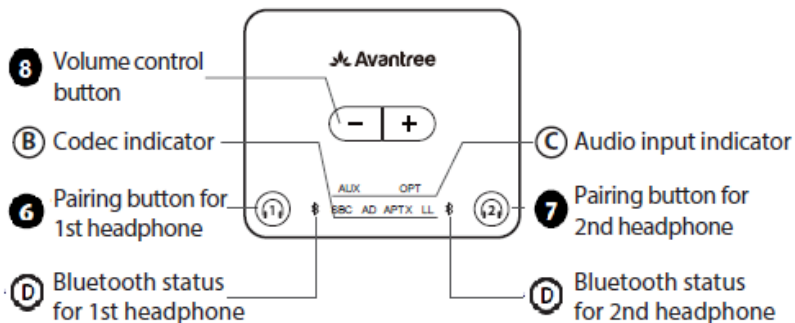
### Product Overview



### Button Functions

No.	Button	Function
5		Switch to "ON / OFF" position to turn the transmitter on / off
6 7		Press and hold for 5s to enter pairing mode for 1st /2nd headphone
		Press and hold for 10s to lock the 1st /2nd headphone when connected
		Press once to activate reconnection
8		Press once to adjust volume
		Press & hold both buttons for 7 seconds to clear pairing history

### LED Indicators

No.	Status	LED Indicator
B	Current codec indicator	Solid white light
C	Valid audio signal	Solid white light
	Invalid audio signal	Flashing white light
D	Pairing	Flashing red & blue alternately
	Connected	Solid blue

## Setting Up

### Connecting to Your TV

The transmitter must be connected to a power source via the provided power cable in order to function. Plug the transmitter into either:

- A TV's USB power port (we recommend this so that they auto power ON / OFF in tandem with your TV), OR
- A nearby wall outlet - 5V / 500mA-2A rated USB charger (e.g. your phone charger should work.) (requires USB adapter, please contact [support@avantree.com](mailto:support@avantree.com) if you'd like to claim a free one)

#### Option 1 - Optical port (recommended)

Plug the provided optical audio cable into the TV's optical OUT or "OPT OUT" port, then plug the other end into the transmitter's optical port.

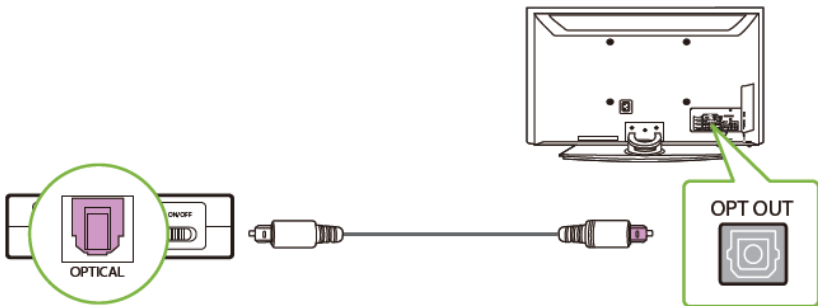

### Option 2 - AUX 3.5mm port

Plug the provided AUX 3.5mm audio cable into the TV's AUX 3.5mm output port, then plug the other end into the transmitter's AUX 3.5mm port.

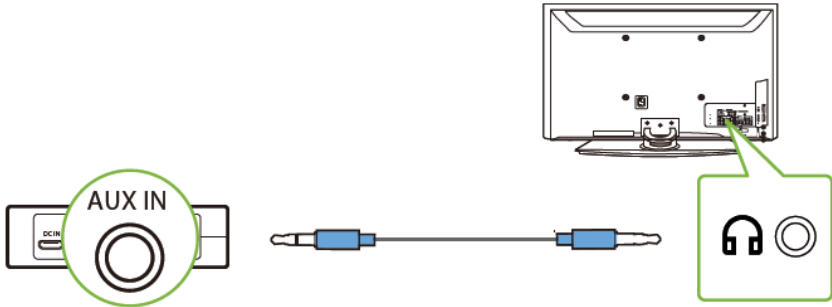

### Option 3 - RCA port

Connect the RCA adapter (not included) to the AUX 3.5mm audio cable. Plug the red & white RCA connectors into the TV's "AUDIO OUT" ports, then plug the other end into the transmitter's AUX 3.5mm port.

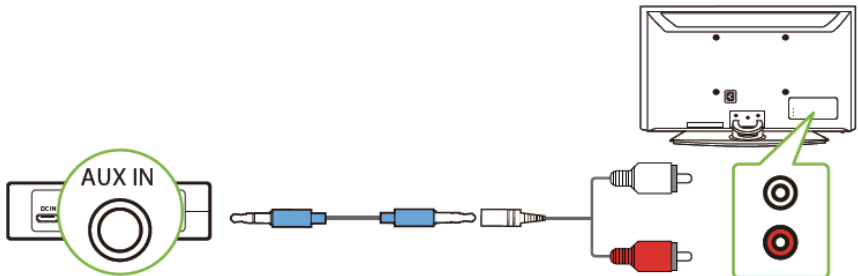



## Connecting the Headphones to the Transmitter

Now that the transmitter is all set up, you can connect the headphones to the transmitter.

### STEP 1



Turn on both headphones, slide the switch to the ON position. The LED indicator should start flashing blue.

### STEP 2



Power the transmitter on by sliding the switch to the ON position.

The  LED will flash blue.

### STEP 3

Keep the headphones close to the transmitter; they should connect within 3-5 seconds. Once connected, the headphones' LED indicator and the  indicator on the transmitter will turn solid blue,

*NOTE: Some smart TVs will automatically scan for and try to pair with any Bluetooth devices in its vicinity. If your TV prompts you to connect your Bluetooth headphones or the transmitter, please "DENY" the request so that your device can properly pair with the transmitter.*

## Setting Up Your TV (FOR OPTICAL CONNECTIONS ONLY)

If you connected to your TV via the optical OUT or “OPT OUT” port, you'll need to configure your TV settings before you'll receive audio.

### STEP 1

Using your TV's remote control, press the SETTINGS button and navigate to the AUDIO tab within the settings menu. (Please note that there may be differences in the setting names depending on your brand of TV).

### STEP 2

Proceed to AUDIO OUTPUT and select “OPTICAL OUT / DIGITAL OUT”. Many TVs will do this automatically; skip this step as needed.

### STEP 3

Set Audio Output format to “PCM / STEREO” ON or “DOLBY” OFF.

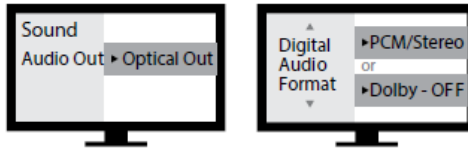

If you're having trouble finding these settings, you can scan the QR code correlating to your TV's brand OR visit [avantree.com/41899/tv-audio-settings](http://avantree.com/41899/tv-audio-settings) for a more detailed guide.



LG



SONY



SAMSUNG

*NOTE 1: Smart TVs automatically reset their settings after system updates. Make sure your audio output / input format is set to "PCM" and NOT "AUTO" or "Dolby."*

*NOTE 2: When using Netflix or Amazon Prime, you may need to start the movie / show before changing the audio settings to "PCM."*

## Charging the Headphones

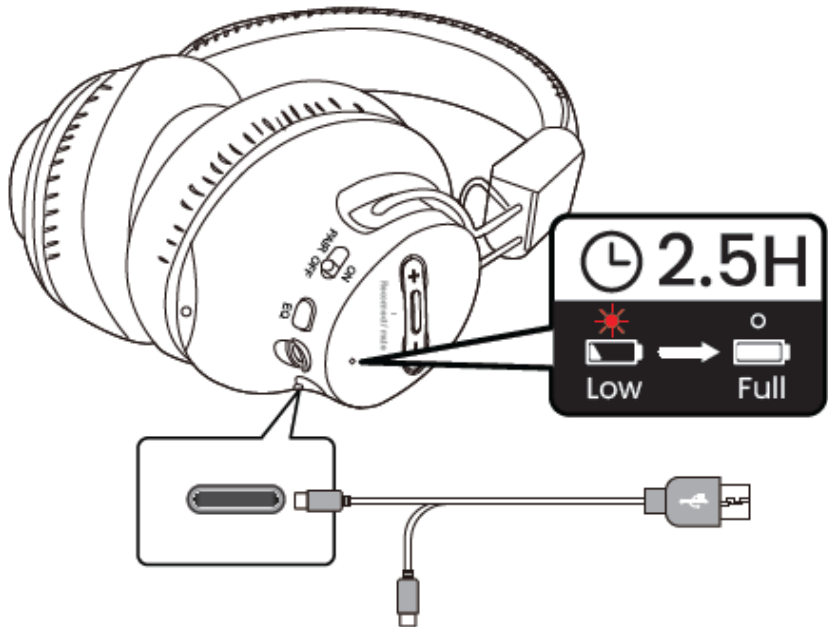

## Advanced Features

### Using the Headphones with Your Phone/Tablet

STEP 1

Turn off or unplug the transmitter.

STEP 2



Turn on the headphones, then slide & hold the switch to the PAIR position until the LED indicator flashes red & blue.

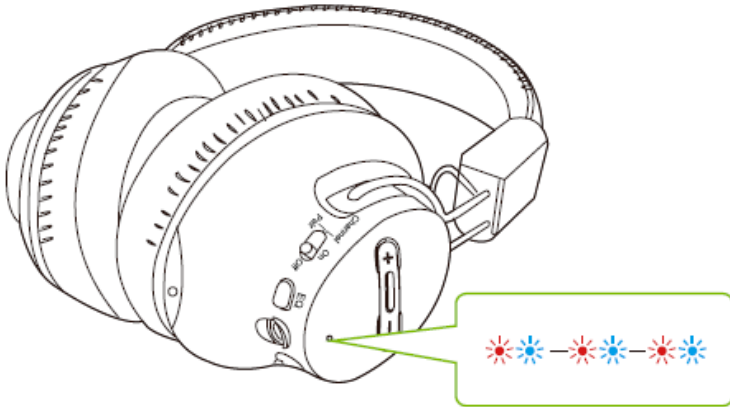

STEP 3

Turn on your audio source's Bluetooth and select "Avantree AS9S" from the Bluetooth menu.

*NOTE: The headphones are factory locked with the transmitter, so they won't automatically reconnect to your phone / tablet. For subsequent use, you can either press the  once, or select "Avantree AS9S" from your phone / tablet's Bluetooth menu.*

## Factory Reset

If you have used them with other devices and are experiencing issues with auto-reconnection, a reset may be necessary.

**Very Important:** turn other devices' Bluetooth off before resetting to avoid interference.

### Reset the transmitter

- Power On the transmitter.
- Press and hold the "+" and "-" buttons simultaneously for 7 seconds. The Bluetooth LED indicators will light up PINK and then turn off, confirming the reset.
- The transmitter will re-enter pairing mode, indicated by the Bluetooth icon next to "1" flashing RED & BLUE.
- Turn the transmitter OFF after resetting.

### Reset the headphones

- Power On each headphone.
- Press and hold the "+" and "-" buttons simultaneously for 10 seconds until both the RED and BLUE LEDs light up together (appearing PINK). This indicates that the reset is complete, and the headphone will automatically enter pairing mode, with the LED flashing alternately RED and BLUE.
- Turn the headphones OFF after resetting.

### Reconnecting

- Turn on both the transmitter and headphones.
- Wait for 5-10 seconds; they should automatically reconnect. You'll see a SOLID BLUE light on both the transmitter and headphones and hear "Connected" from the headphones.

## Specifications

### Transmitter

Bluetooth version	v5.3
Frequency response	20Hz-20KHz
Operating range	Up to 164ft/50m
Bluetooth profiles	A2DP, AVRCP
Supported audio codecs	aptX adaptive, aptX-LL, aptX, SBC

### Headphones

Bluetooth version	v5.2
Frequency response	20Hz-20KHz
Bluetooth profiles	A2DPv1.3.1, AVRCP v1.6, HSPv1.2, HFP v1.7.1
Supported audio codecs	aptX adaptive SBC AAC aptX aptX HD
Battery life	Up to 60 hours
Impedance	32Ω
Net weight	200g

## FAQ

Below are some of the most common questions people have during setup.

### **I have a Samsung / LG TV. Why are my headphones failing to reconnect to the transmitter?**

Samsung / LG smart TVs tend to pair with any Bluetooth devices they can find, which blocks the Avantree headphones from reconnecting to its transmitter.

Try following the steps below in order to fix this:

**DENY the Device** - If a popup appears on your TV asking you to Allow or Deny / Block the device to connect to the TV, you MUST DENY / BLOCK the device from connecting.

**REMOVE the Device** - If your device is already paired with the TV, you'll need to remove the device in your TV's settings: SETTINGS > GENERAL > EXTERNAL DEVICE MANAGER>DEVICE CONNECTION MANAGER > DEVICE LIST > EDIT >Select all Avantree devices >DELETE.

Please note that the routing may differ based on your TV's brand / model.

**Turn OFF the TV** - Physically turn your TV OFF or pull the plug (the remote control does NOT turn the TV off; it places it into standby mode which still allows the TV to connect to devices).

### **Can I have audio through my TV's speakers and wireless headphones at the same time?**

This completely depends on whether or not your TV supports the ability to output audio to 2 devices simultaneously. You can try a few different methods to test if your TV is capable of this or not -- please refer to

[avantree.com/pages/support/ht41899-bluetooth-dual-headphones-tv-set](http://avantree.com/pages/support/ht41899-bluetooth-dual-headphones-tv-set) for more details.

## Contact us



[avantree.com/submit-a-ticket](https://avantree.com/submit-a-ticket)

---



[support@avantree.com](mailto:support@avantree.com)

---



US	+1 800 232 2078	9am-5pm PST	Mon-Fri
CA	+1 800 232 2078	9am-5pm PST	Mon-Fri
UK	+44 208 068 2023	9am-6pm GMT	Mon-Fri
DE	+49 322 2109 7297	10am-5pm CET	Mon-Fri
FR	+33 17 634 0312	10am-5pm CET	Mon-Fri
IT	+39 069 4803 330	10am-5pm CET	Mon-Fri
ES	+34 93 1786 261	10am-5pm CET	Mon-Fri
AU	+61 2 8310 9897	11am-7pm AEST	Mon-Fri

---



[avantree.com/support/41899](https://avantree.com/support/41899)

---



Scan QR code on the product to register for 24-month warranty.