

Aria 3

User Manual



Model No.: BTHS-A592

Table of Contents

Box Contents	3
Product Introduction	3
Product Overview.....	3
Button Functions.....	4
LED Indicators.....	5
Charging the Headphones	6
Connecting the Headphones to Your Device	7
Using with Your Phone.....	7
Using with Your PC.....	8
Configuring Audio Settings (Only for PC).....	9
Specifications	11
Contact Us	53

Box Contents



Aria 3
Headphones

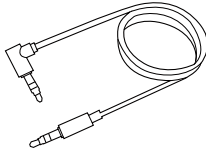

AUX 3.5mm
Audio Cable

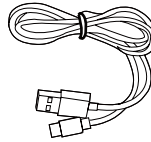

Type C
Charging Cable

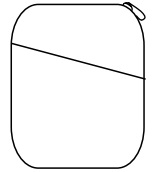

Carrying Pouch

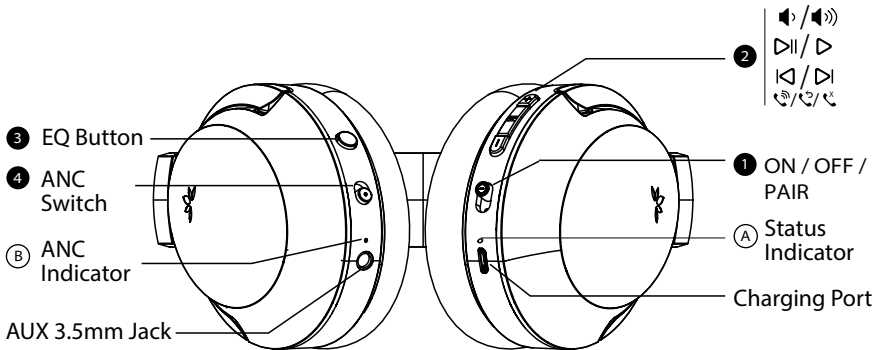

Product Introduction

Product Overview



Button Functions

Headphones

No.	Button	Functions
1		Switch to the "ON / OFF" position to turn the headphones on / off
		Switch to the "PAIR" position & hold for 2 seconds to enter pairing mode
2		Press once to play / pause
		Press once to accept / end call
		Press & hold for 2 seconds to reject call
		Press twice to redial last number
		Press once to increase / decrease volume
		Press & hold for 2 seconds to skip / replay track
Press & hold both buttons for 5 seconds to clear pairing history		
3	EQ	Press once to switch between Bass/Normal mode
4	ANC	Switch to turn the Active Noise Cancellation on / off
2 / 3	EQ and + / -	Press & hold "EQ & +" or "EQ & -" for 1 second to turn the voice prompt on / off

LED Indicators

No.	Indicator & Voice Prompt	Status
A	Solid red	Charging
	Flashing red, "LOW BATTERY" voice indicator	Low battery
	Blue flash every 2 seconds, "WELCOME TO AVANTREE" voice indicator	Power on
	Solid red for 1 second then off, "GOODBYE" voice indicator	Power off
	Alternate red & blue flashes, "PAIRING" voice indicator	Pairing
	Blue flash every 5 seconds, "CONNECTED" voice indicator	Connected
	Blue flash every 2 seconds, "DISCONNECTED" voice indicator	Disconnected
	Solid pink for 5 seconds, then alternate red & blue flashes	Clearing pairing history
B	Solid green, "NOISE CANCELING" voice indicator	Active Noise Cancellation (ANC) mode

Charging the Headphones

A "LOW BATTERY" voice prompt and a flashing red **A** light indicates low battery. In order to charge, you can use either a 5V/500mA-2A rated USB adapter (your phone charger or similar should work) or PC USB port as a power source.

Plug the provided type C power cable directly into the headphones' charging port.

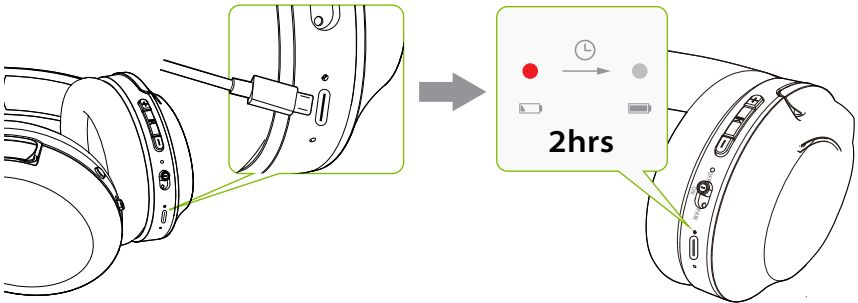

A solid red light indicates that charging is in progress; once the light turns off, your headphones will be at full battery.

Connecting the Headphones to Your Device

Using with Your Phone

STEP 1

Turn on the headset. It will enter pairing mode automatically on the first use. Otherwise, slide and hold the power switch to the "PAIR" position until you hear "Pairing" and see the LED flashing RED & BLUE.

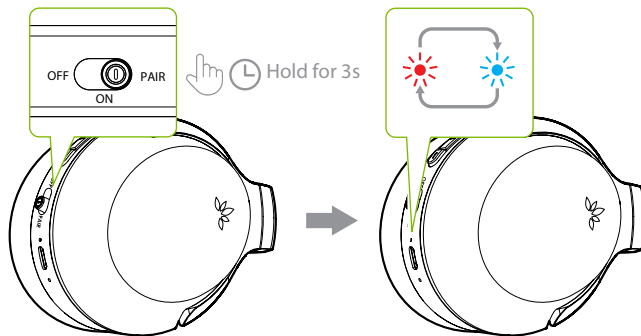



STEP 2

Turn on your device's Bluetooth and select "Avantree Aria 3" in the Bluetooth menu.

STEP 3

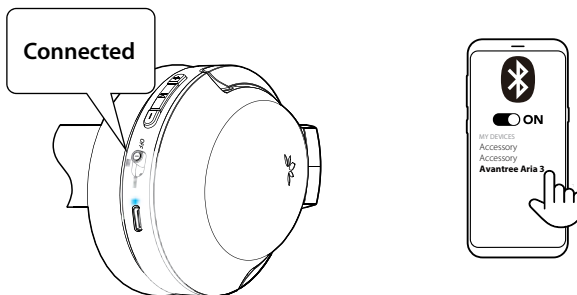
Keep the headphones close to your device and wait for 5-10 seconds or until they connect. Once they're successfully connected, you'll hear a "CONNECTED" voice indicator on headphones. The headphones' LED indicator will flash blue, then turn solid blue once you play audio.



For subsequent use, your headphones should automatically reconnect to the last-paired device within a few seconds of being turned on. If not, you can manually activate reconnection by sliding the OFF  PAIR switch to "PAIR" once, or by selecting "Avantree Aria 3" in your device's Bluetooth menu.

Using with Your PC

To connect the headphones to your PC, follow these steps:

STEP 1

Turn on the headset. It will enter pairing mode automatically on the first use. Otherwise, slide and hold the power switch to the "PAIR" position until you hear "Pairing" and see the LED flashing RED & BLUE.

STEP 2

Go to your computer's Bluetooth settings and search for the Avantree device. Click "Connect".

STEP 3

Keep the devices close together. Once successfully connected, the headset's LED will turn solid blue, and you will hear a "Connected" voice indicator.

For subsequent use, the headset should automatically reconnect to the last paired device within a few seconds after turning on. If not, manually reconnect by sliding the power switch to “PAIR” once or selecting “Avantree” from your device’s Bluetooth menu.

Configuring Audio Settings (Only for PC)

You may need to configure your audio settings when using the Aria 3 with your PC or laptop.

STEP 1

In your device’s audio settings, ensure that “Avantree Aria 3” is selected as the default for both SOUND OUTPUT / PLAYBACK and INPUT / MICROPHONE device.

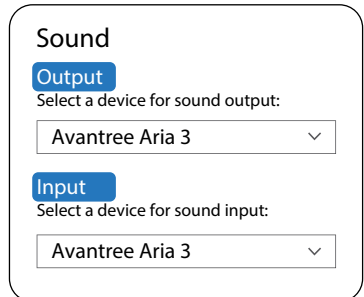
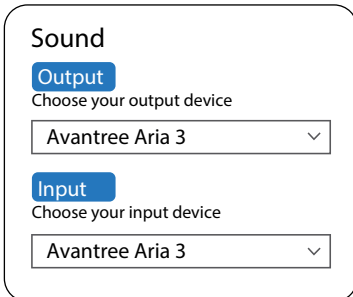
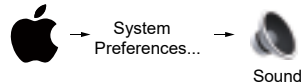
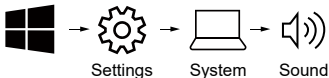

STEP 2

Repeat the above steps in your meeting software (i.e. Teams, Zoom, Skype, etc.)

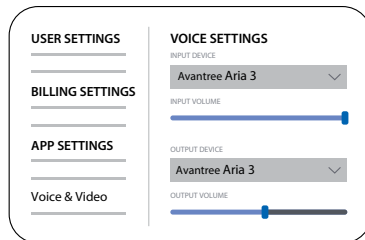
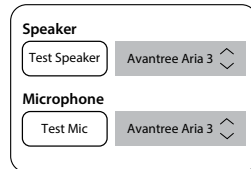
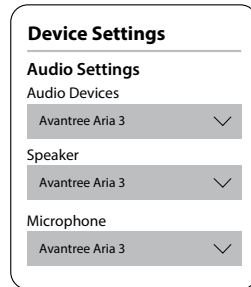
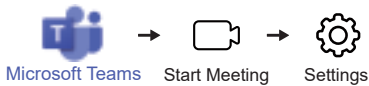

NOTE: On Windows 7 / 8.1 / 10, if you use headphones with PC's built-in Bluetooth, select "Avantree Aria 3 hands free" as the default instead.

Specifications

Headphones

Bluetooth version	v5.3
Supported audio codecs	SBC
Supported profiles	HSP v1.2, HFP v1.7, AVRCP v1.6, A2DP v1.3.1
Operating range	Up to 30ft / 10m
Drivers	40mm
Impedance	32Ω
Frequency response	20Hz - 20KHz
Charging time	~2hrs
Operating time	Up to 55hrs (ANC off)
Standby time	325hrs (ANC off)
Product size	190mm x 175mm x 80mm
Headphones weight	~230g
Earpads inner diameter / depth	60mm x 40mm x 35mm
Earpads outer diameter	101mm x 80mm
Rated input	DC5V/500mA~2.0A
Power port	Type C

Contact Us



Support Tickets avantree.com/submit-a-ticket



Support Email support@avantree.com



Support Numbers

US	+1 800 232 2078	9am-6pm PST	Mon-Fri
CA	+1 800 232 2078	9am-6pm PST	Mon-Fri
UK	+44 208 068 2023	9am-6pm GMT	Mon-Sat
DE	+49 322 2109 7297	11am-9pm CET	Mon-Sat
FR	+33 17 634 0312	11am-9pm CET	Mon-Sat
IT	+39 069 4803 330	9am-6pm CET	Mon-Sat
ES	+34 93 1786 261	9am-6pm CET	Mon-Sat
AU	+61 2 8310 9897	11am-7pm AEST	Mon-Fri



FAQ avantree.com/support/aria3



Product Registration See QR code on the product.

Manufacturer:
Avantronics Limited
Luohu District, Shenzhen 518000 China
+ 86 755 8228 5022 support@avantree.com

US Importer:
Avantree Corporation
San Jose, California 95119 USA
+1 800 232 2078 support@avantree.com

UK Importer:
Avantree Limited
Watford, WD180 0HQ UK
+44 20 8068 2023 support@avantree.com



Service in Europe:
Gizmex GmbH,
Sternstr. 67, 40479 Dusseldorf, Germany
+49 322 2109 7297 support@avantree.com



Model No.: BTHS-AS92
Dispose of the packaging and this product in accordance with the latest provisions.
Z-PKQG-AS92-V0