

HT3831

User Manual



Model No.: WSHT-3831

Table of Contents

Box Contents	3
Product Introduction (Earbuds)	4
Product Overview	4
Button Functions.....	5
LED Indicators	5
Product Introduction (Transmitter & Charging Dock)	6
Product Overview	6
Button Functions.....	7
LED Indicators	8
Setting Up	9
Connecting to Your TV	9
Connecting the Earbuds to the Transmitter.....	11
Setting Up Your TV.....	11
Advanced Features	13
Listening with an AV Receiver	13
Adding More HT381 Earbuds.....	14
Charging the Earbuds	15
Specifications	17
FAQ	18
Contact Us	93

Box Contents

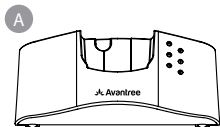

A
Wireless Transmitter &
Charging Dock

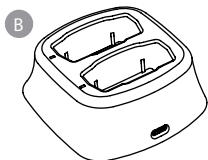

B
Dual Charging
Dock

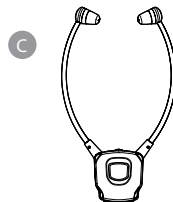

C
HT381 Earbuds x3

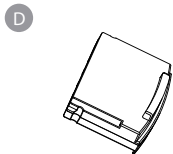

D
Spare Battery

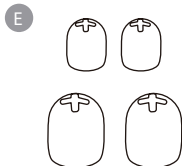

E
Earbuds tips
(M / S) x6

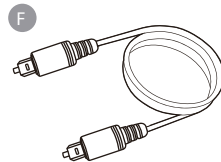

F
Optical Audio Cable

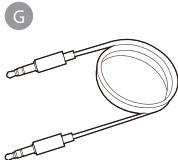

G
3.5mm AUX
Cable

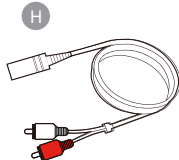

H
3.5mm AUX to
RCA Adapter

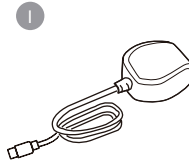

I
Wall
Adapter x2

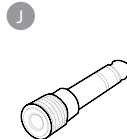



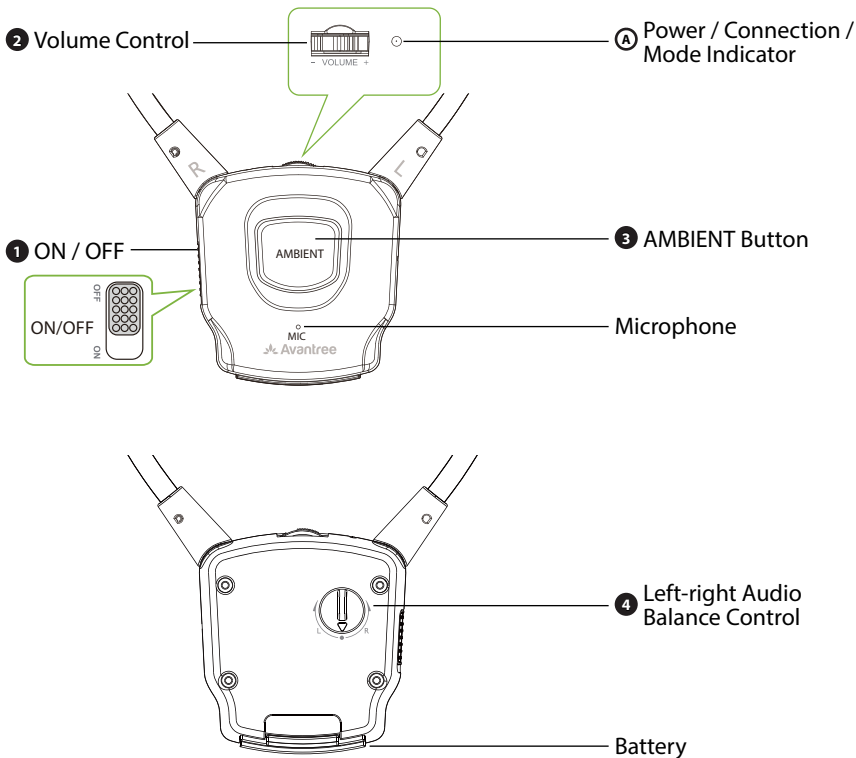

J
6.35mm to
3.5mm Adapter

Product Introduction (Earbuds)

Product Overview



Button Functions

No.	Button	Functions
1		Switch to the "ON / OFF" position to turn the earbuds on / off
2		Roll to "+ / -" to increase / decrease volume
3		Click once to enter / exit AMBIENT mode to amplify surrounding sound
		Hold for 5 seconds to get the earbuds into pairing mode
4		Turn to "L / R" to boost the audio on the left or right side depending on your needs

LED Indicators

No.	Indicators & Voice Prompt	Status
A	Green flashes twice every second	Pairing
	Solid green	Connected
	Green flashes every 5 seconds	Disconnected
	Solid red	AMBIENT mode on

Product Introduction (Transmitter & Charging Dock)

Product Overview

Spare Battery Charging Slot
Charging Cradle

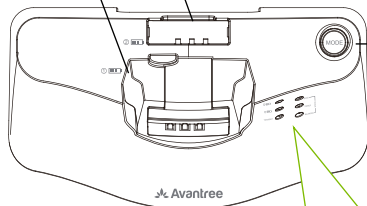

① Mode / Pair Button

Ⓐ Spare Battery Charging Indicator

Ⓑ Earbuds Charging Indicator

Ⓒ Power / Connection Indicator

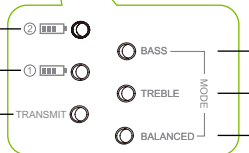

Ⓓ Bass / Treble /
Balanced Mode
Indicator

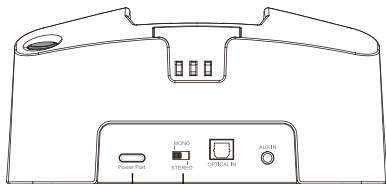

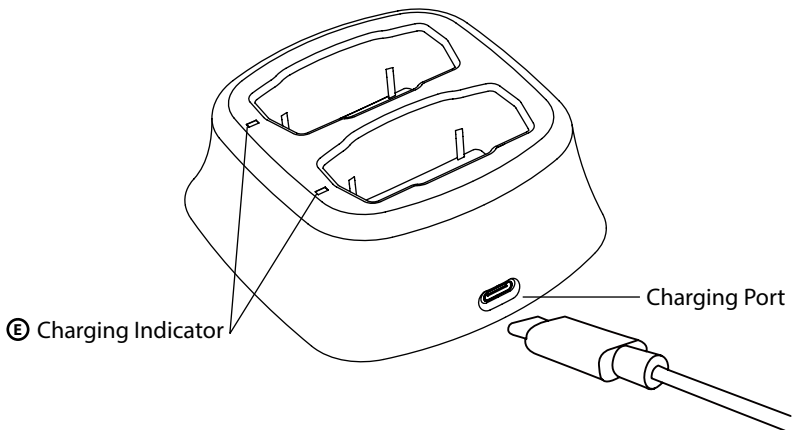

Power Port

② Stereo/Mono Switch



Button Functions

No.	Button	Functions
1		Click once to switch between BASS / TREBLE / BALANCED modes. Long press for 2 seconds to enter pairing mode
2		Switch between "Stereo / Mono". Switch to "mono" mode for combined audio output, suitable for SSD users

LED Indicators

No.	Indicators	Status
A	Solid red	Spare battery charging
	Solid green	Spare battery fully charged
B	Solid red	Earbuds charging
E	Solid green	Earbuds fully charged
C	Solid Green	Power on / Connected
	Flashing green rapidly	Pairing mode
D	Solid orange	Bass / Treble / Balanced EQ Mode

Setting Up

Connecting to Your TV

The transmitter dock must be connected to a power source using the provided power cable and charger in order to function. Once the transmitter dock is connected to a power source, you can connect it to your TV. You can choose one of 2 different ways to do this:

OPTION 1 Optical port (recommended)

Plug the provided optical audio cable into the TV's optical OUT or "OPT OUT" port, then plug the other end into the transmitter's optical port.

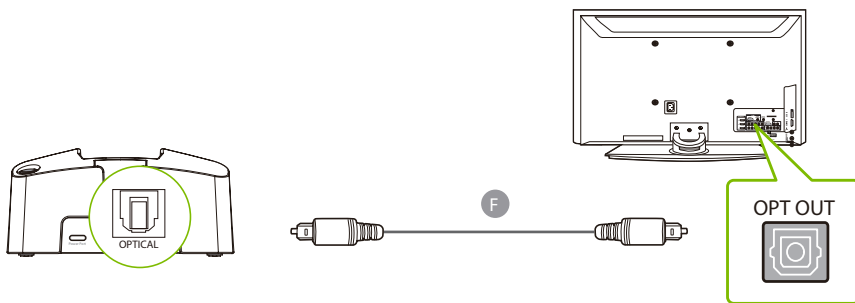

NOTE: Most TVs support audio output through only one digital output port at a time, so if your TV's HDMI ARC port is in use, the optical port may be disabled. You can either disconnect the HDMI ARC device, or try connecting the transmitter via RCA / AUX.

OPTION 2 AUX 3.5mm port

Plug the provided AUX 3.5mm audio cable into the TV's AUX 3.5mm output port, then plug the other end into the transmitter's AUX 3.5mm port.

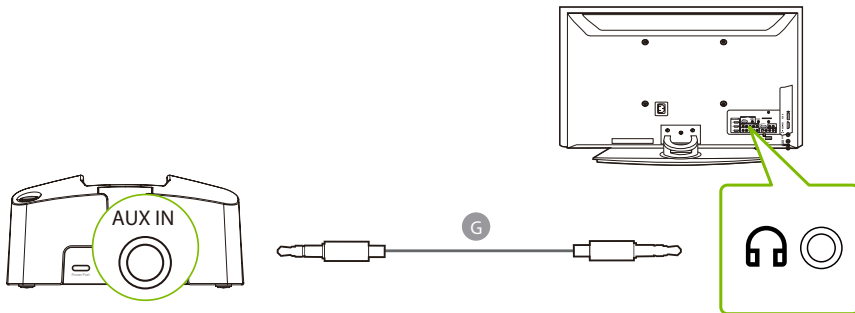
**OPTION 3** RCA port

Attach the provided RCA adapter to the AUX 3.5mm audio cable. Plug the red & white RCA connectors into the TV's "AUDIO OUT" ports, then plug the other end into the transmitter's AUX 3.5mm port in the "INPUT FROM TV" section.

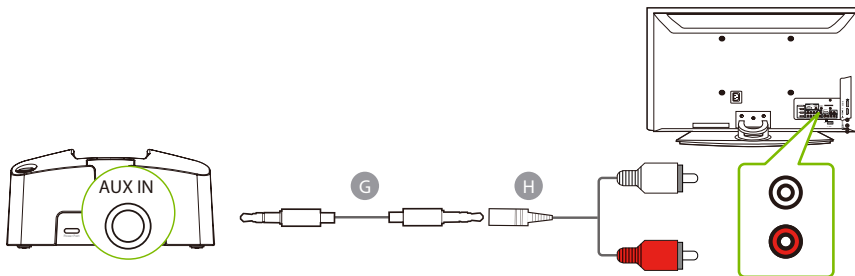

Connecting the Earbuds to the Transmitter

STEP 1

Power on the earbuds by sliding the  to the "ON" position.

STEP 2

Keep the earbuds close to the transmitter; they should connect within 2-5 seconds. Once connected, both the LED indicator on the earbuds and the LED indicator on the transmitter will turn solid green.

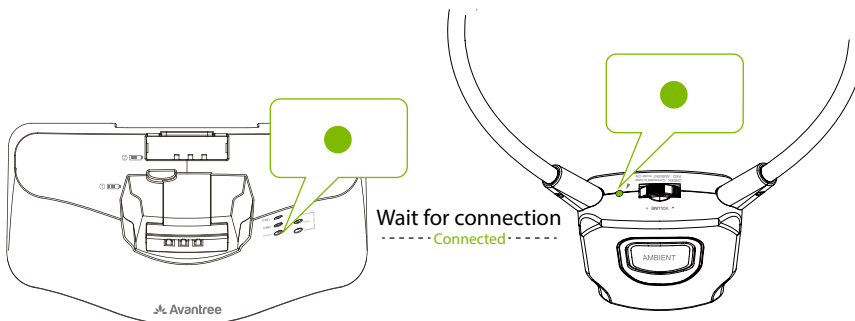

Setting Up Your TV (FOR OPTICAL CONNECTIONS ONLY)

If you connected to your TV via the optical OUT or "OPT OUT" port, you'll need to configure your TV settings in order to receive audio.

STEP 1

Using your TV's remote control, press the SETTINGS button and navigate to the AUDIO tab within the settings menu. (Please note the settings names may vary depending on your brand of TV).

STEP 2

Proceed to AUDIO OUTPUT and select "OPTICAL OUT / DIGITAL OUT". Many TVs will do this automatically; skip this step as needed.

STEP 3

Set the AUDIO OUTPUT format to "PCM / STEREO" ON or "DOLBY" OFF.

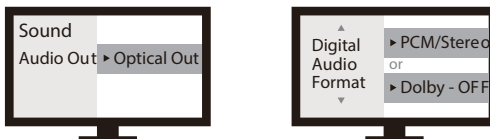

If you're having trouble finding these settings, you can scan the QR code of your TV's brand below OR visit avantree.com/3831/tv-audio-settings for a more detailed guide.



LG



SONY



SAMSUNG

NETFLIX/
AMAZON PRIME

NOTE 1: Smart TVs automatically reset their settings after system updates. If you're not getting sound, make sure your audio output / input format is set to "PCM" and NOT "AUTO" or "Dolby."

NOTE 2: When using Netflix or Amazon Prime, you may need to start the movie / show first before changing the audio settings to "PCM."

Advanced Features

Listening with an AV Receiver

The HT3831 comes with one 6.35mm to 3.5mm audio adapter and one AUX 3.5mm audio cable that you can use with your AV Receiver.

STEP 1

Plug a 3.5mm AUX audio cable into the transmitter's AUX 3.5mm port in the "INPUT FROM TV" section.

STEP 2

Attach the 6.35mm to 3.5mm audio adapter, then plug it to the "Phones" jack at the front of your AV Receiver, now you're good to go.

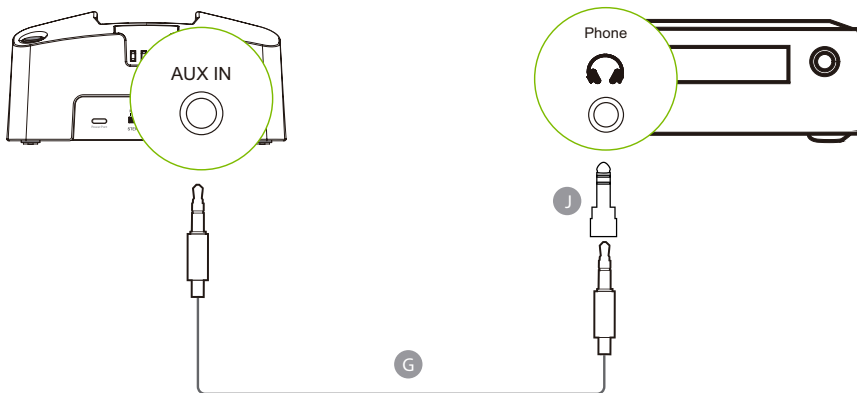

Adding More HT381 Earbuds

The HT3831 transmitter can connect up to 100 pairs of earbuds. Follow these steps to connect four or more HT381 earbuds to the transmitter:

STEP 1

On your transmitter, press & hold the “MODE” button for 2 seconds. The “TRANSMIT” LED indicator will flash green.

STEP 2

Turn on the fourth pair of HT381 earbuds, then press and hold the “AMBIENT” button on the earbuds for 5 seconds until the LED indicator starts flashing green rapidly.

STEP 3

Hold them close together and wait. Once connected, the earbud’s connection LED indicator will turn solid green.

Repeat these steps to add up to 100 earbuds to your setup.

To purchase HT381 Extra earbuds, scan the QR code below.



Charging the Earbuds

When the earbuds' battery is low, you'll start hearing "beeps" three times per minute and the LED will flash green rapidly. Please charge the earbuds when this happens. There are 2 ways to charge the earbuds.

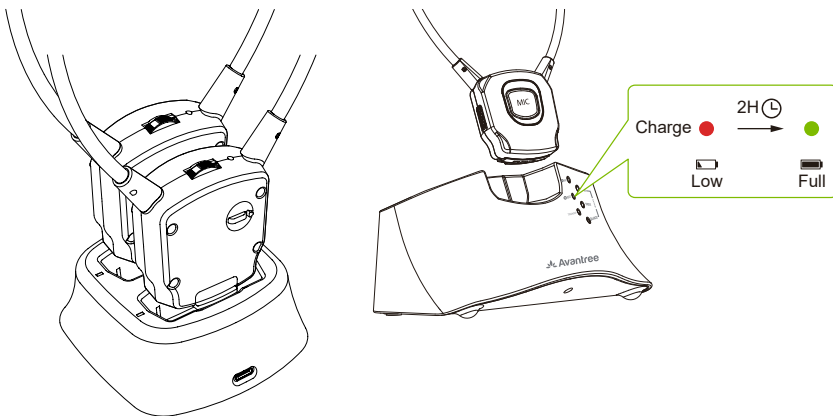

OPTION 1 Charging via the transmitter & dual charging dock

While the transmitter and the dual charging dock are connected to power, place the earbuds back into them. The charging indicators will turn red while charging. Once fully charged, they will turn green.



OPTION 2 Swapping in the spare battery

The HT3831 set comes with an extra battery. Simply swap in that extra battery, and insert the drained battery into the battery charging dock to charge.

The ②   indicator on the front side of the transmitter dock will turn red when the battery is charging and turn green when the charging is complete.

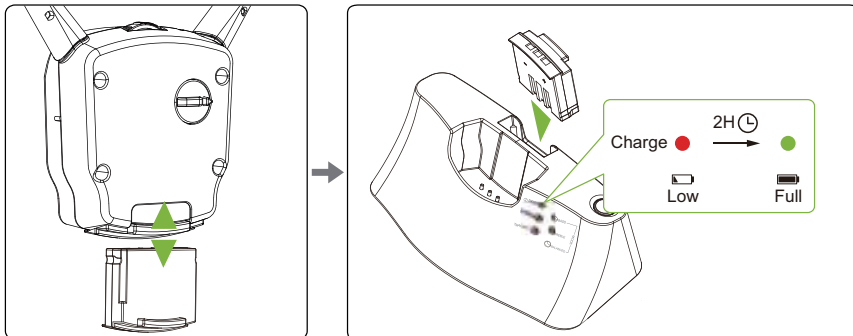

NOTE : Before use, please turn the HT381 earbuds on manually before taking them out of the charging dock.
After use, please turn the HT381 earbuds off manually before putting them back into the charging dock.

Specifications

Transmitter

Carrier Frequency	2.4GHz
Operating range	Up to 100ft / 30m
Operating Voltage	5V
Supported audio format in optical mode	PCM / LPCM
Power port	Type C
Rated input	DC5V/500mA~2.0A
Weight	157g

Earbuds

Carrier Frequency	2.4GHz
Operating range	Up to 30ft / 10m
Operating Voltage	3.7V Lithium Polymer Battery
Play time	Up to 8 hrs
Charging time	~2hrs
Weight	72g

FAQ

Below are some of the most common questions people have during setup.

Can I have audio through my TV's speakers and wireless headphones at the same time?

This completely depends on whether or not your TV supports the ability to output audio to 2 sources simultaneously. You can try a few different methods to test if your TV is capable of this or not - please refer to avantree.com/3831/sound for more details.

My headphones have no sound when connected to the transmitter – what do I do?

Check to ensure your earbuds are successfully connected to the Transmitter. Once connected, both the LED indicator on the earbuds and the-TRANSMIT  LED indicator on the transmitter will turn solid green.

If you're still not receiving sound, check that the proper audio signal is being sent to the transmitter.

If using an RCA / AUX connection, set your TV's audio output settings to "Headphone" or "External Speakers." If using an OPT connection, turn "PCM / STEREO" ON or "DOLBY" OFF.

For RCA / AUX connections, you can also connect the TV's output port directly to a pair of headphones and test for audio. If there's no sound, then that probably means your TV's port is defective.

For answers to questions like these and for a full FAQ list, you can visit avantree.com/support/3831, or you can contact us directly for additional assistance.

Contact Us



Support Tickets avantree.com/submit-a-ticket



Support Email support@avantree.com



Support Numbers

US	+1 800 232 2078	9am-6pm PST	Mon-Fri
CA	+1 800 232 2078	9am-6pm PST	Mon-Fri
UK	+44 208 068 2023	9am-6pm GMT	Mon-Sat
DE	+49 322 2109 7297	11am-9pm CET	Mon-Sat
FR	+33 17 634 0312	11am-9pm CET	Mon-Sat
IT	+39 069 4803 330	9am-6pm CET	Mon-Sat
ES	+34 93 1786 261	9am-6pm CET	Mon-Sat
AU	+61 2 8310 9897	11am-7pm AEST	Mon-Fri



FAQ avantree.com/support/3831



Video Guide avantree.com/3831/video



Product Registration See QR code on the product.

Manufacturer:
Avantronics Limited
Luohu District, Shenzhen 518000 China
+ 86 755 8228 5022 support@avantree.com

US Importer:
Avantree Corporation
San Jose, California 95119 USA
+1 800 232 2078 support@avantree.com

UK Importer:
Avantree Limited
Watford, WD180 0HQ UK
+44 20 8068 2023 support@avantree.com



Servicer in Europe:
Gizmex GmbH,
Sternstr. 67, 40479 Dusseldorf, Germany
+49 322 2109 7297 support@avantree.com



Model No.: WSHT-3831
Dispose of the packaging and this product in accordance with the latest provisions.
Z-PKQG-3831-V0