

# Quartet

## User Manual



Model No.: WSHT-5049

**EN**

## Video Guide

Prefer to watch a video tutorial? Scan the QR code below or visit [avantree.com/quartet/video](https://avantree.com/quartet/video) for a step-by-step guide.

**DE**

## Video-Anleitung

Möchten Sie lieber ein Video-Tutorial ansehen? Scannen Sie den QR-Code unten oder besuchen Sie [avantree.com/quartet/video](https://avantree.com/quartet/video) für eine Schritt-für-Schritt-Anleitung.

**FR**

## Guide Vidéo

Vous préférez un didacticiel vidéo? Scannez le code QR ci-dessous ou visitez [avantree.com/quartet/video](https://avantree.com/quartet/video) pour un guide pas à pas.

**IT**

## Videoguida

Preferisci guardare un video tutorial? Scansiona il codice QR qui sotto o visita [avantree.com/quartet/video](https://avantree.com/quartet/video) per una guida dettagliata.

**ES**

## Videoguía

Prefieres ver un video tutorial? Escanee el código QR a continuación o [avantree.com/quartet/video](https://avantree.com/quartet/video) para obtener una guía detallada.



**EN**

## Book an Appointment

You can also book a 1-on-1 setup appointment with one of our support agents at [avantree.com/book-a-call](https://avantree.com/book-a-call)

**DE**

## Buchen Sie einen Termin

Vereinbaren Sie einen persönlichen Einrichtungstermin mit einem Support-Mitarbeiter unter [avantree.com/book-a-call](https://avantree.com/book-a-call) und wählen Sie Ihre passende Zeit.

**FR**

## Prenez Rendez-Vous

Vous pouvez également réserver un rendez-vous d'installation individuel avec l'un de nos agents de support via [avantree.com/book-a-call](https://avantree.com/book-a-call)

**IT**

## Prendi un Appuntamento

Puoi anche prenotare un appuntamento con uno dei nostri agenti del supporto tecnico su: [avantree.com/book-a-call](https://avantree.com/book-a-call)

**ES**

## Haga una Cita

También puede reservar una cita con uno de nuestros agentes de soporte técnico en: [avantree.com/book-a-call](https://avantree.com/book-a-call)



# Table of Contents

<b>Box Contents</b> .....	3
<b>Product Introduction (Headphones)</b> .....	4
Product Overview .....	4
Button Functions .....	4
LED Indicators .....	5
<b>Product Introduction (Transmitter)</b> .....	5
Product Overview .....	5
Button Functions.....	6
LED Indicators .....	6
<b>Setting Up</b> .....	7
Connecting to Your TV .....	7
Connecting the Headphones to the Transmitter .....	10
Setting Up Your TV(For Optical Connections Only) .....	10
<b>Charging the Headphones</b> .....	12
<b>Advanced Features</b> .....	13
Listening with a Soundbar .....	13
Adding More Headphones.....	14
<b>Specifications</b> .....	15
<b>FAQ</b> .....	16
<b>Contact Us</b> .....	81

# Box Contents



Headphones x 4



Transmitter

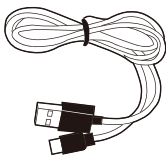

Power Cable for Transmitter

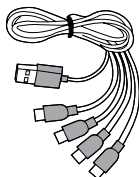

4 in 1 Charging Cable for Headphones

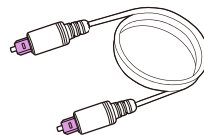

Optical Audio Cable

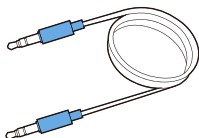

AUX 3.5mm Audio Cable

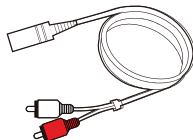

AUX 3.5mm to RCA Adapter

To purchase Quartet accessories, please visit [avantree.com/quartet/accessories](http://avantree.com/quartet/accessories)

# Product Introduction (Headphones)

## Product Overview

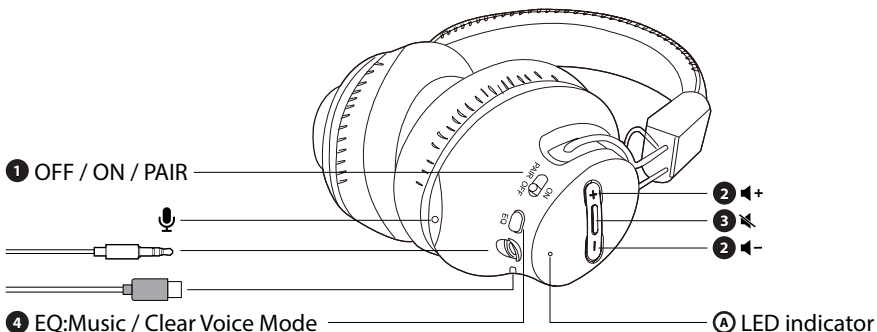

## Button Functions

No.	Button	Functions
1	OFF <input type="checkbox"/> PAIR ON <input type="checkbox"/>	Switch to the "ON / OFF" position to turn the headphones on / off Hold in the "PAIR" position for 3 seconds to enter pairing mode
2	<input type="button" value="+"/> <input type="button" value="-"/>	Press or hold to adjust volume
3	<input type="button" value="+"/> <input type="button" value="-"/>	Press once to mute / unmute the headphones
4	EQ <input type="button" value="EQ"/>	Press once to switch between balanced and clear voice modes

## LED Indicators





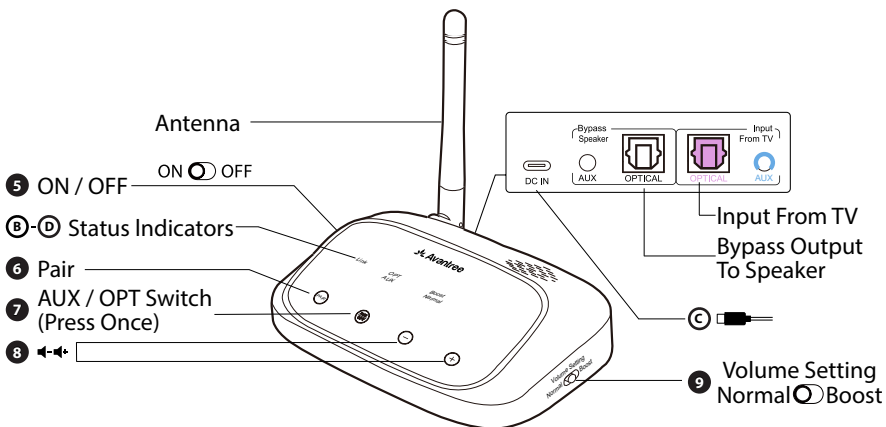

No.	Status	LED Indicator
A	Power ON	Flashing Blue
	Power OFF	Off
	Pairing	Flashing Blue Rapidly
	Connected	Solid Blue
	Low battery	Flashing Red
	Charging	Solid Red
	Charging complete	Off

## Product Introduction (Transmitter)

### Product Overview



## Button Functions

No.	Button	Functions
<b>5</b>	ON  OFF	Switch to turn the transmitter on / off
<b>6</b>		Press & hold for 2 seconds to add more Quartet-Extra headphones
<b>7</b>		Press once to switch between AUX / OPT audio input
<b>8</b>	 	Press once to adjust volume
<b>9</b>	Normal  Boost	Switch between Normal and Boost mode

## LED Indicators

No.	Indicator	Status
<b>B</b>	Solid white	Power on / Connected
	Flashing white	Pairing mode
<b>C</b>	AUX solid white	AUX audio signal
	OPT solid white	OPT audio signal
<b>D</b>	Solid white light	Volume mode - boosted / normal



# Setting Up

## Connecting to Your TV

The transmitter must be connected to a power source via the provided power cable in order to function. Plug the transmitter into either:

- A TV's USB port (we recommend this so that the transmitter auto powers ON / OFF in tandem with your TV), OR
- A nearby wall outlet - 5V/500mA-2A rated USB charger (requires a USB adapter, your phone charger should work. Please contact support@avantree.com if you'd like to claim a free one)

Once the transmitter is connected to its power source, slide the ON  OFF switch to the ON position and connect the transmitter to your TV.

You can choose one of 3 different ways to do this:

### OPTION 1 Optical port (recommended)

#### STEP 1

Plug the provided optical audio cable into the TV's optical OUT or OPT OUT port, then plug the other end into the transmitter's optical port in the "INPUT FROM TV" section.

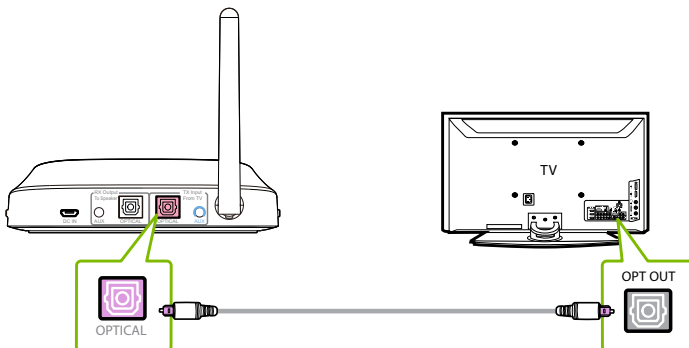

**NOTE:** Most TVs support audio output through only one digital output port at a time, so if your TV's HDMI ARC port is in use, the optical port may be disabled. You can either unplug the HDMI ARC device, or try connecting the transmitter via RCA / AUX.

## STEP 2

Check the transmitter's audio signal indicators and ensure that "OPT" is lit up. If it isn't, press the  button.

### OPTION 2 AUX 3.5mm port

## STEP 1

Plug the provided AUX 3.5mm audio cable into the TV's AUX 3.5mm output port, then plug the other end into the transmitter's AUX 3.5mm port in the "INPUT FROM TV" section.

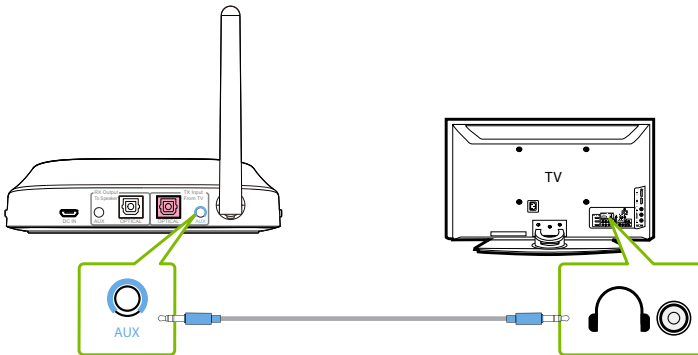

## STEP 2

Check the transmitter's audio signal indicators and ensure that "AUX" is lit up. If it isn't, press the  button.

**OPTION 3** RCA port**STEP 1**

Connect the provided RCA adapter to the AUX 3.5mm audio cable. Plug the red & white RCA connectors into the TV's "**AUDIO OUT**" ports, then plug the other end into the transmitter's AUX 3.5mm port in the "INPUT FROM TV" section.

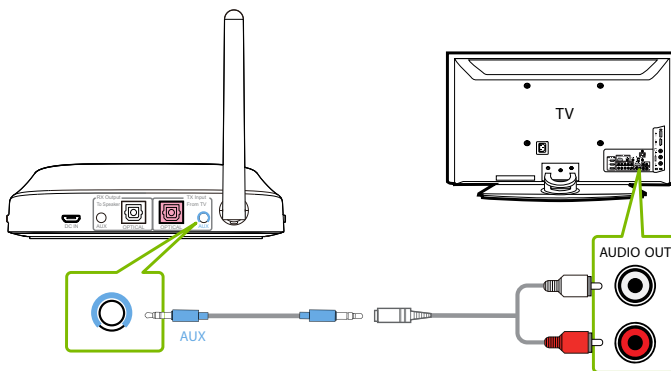

*NOTE : Double check to ensure that optical / RCA cables are plugged into the TV's audio OUT ports and not the AUDIO IN / COMPONENT IN ports.*

**STEP 2**

Check the transmitter's audio signal indicators and ensure that "AUX" is lit up. If it isn't, press the  button.

## Connecting the Headphones to the Transmitter

### STEP 1

Power the transmitter on by sliding the ON  OFF switch to the ON position.

### STEP 2

On your headphones, slide the OFF  PAIR switch to the ON position.

### STEP 3

Keep the headphones close to the transmitter; they should connect within 2-5 seconds. Once connected, the headphones' LED indicator will turn solid blue.

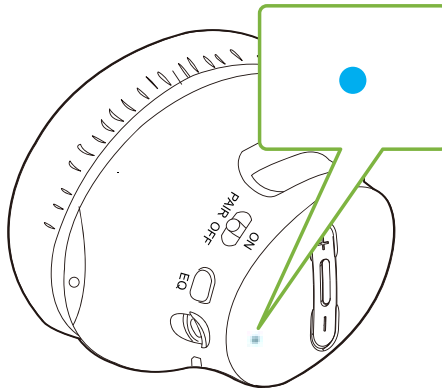

## Setting Up Your TV(For Optical Connections Only)

If you connected to your TV via the optical OUT or "OPT OUT" port, you'll need to configure your TV settings in order to receive audio.

**STEP 1**

Using your TV's remote control, press the SETTINGS button and navigate to the AUDIO tab within the settings menu. (Please note that there may be differences in the setting names depending on your brand of TV).

**STEP 2**

Proceed to AUDIO OUTPUT and select "OPTICAL OUT / DIGITAL OUT". Many TVs will do this automatically; skip this step as needed.

**STEP 3**

Set Audio Output format to "PCM / STEREO" ON or "DOLBY" OFF.

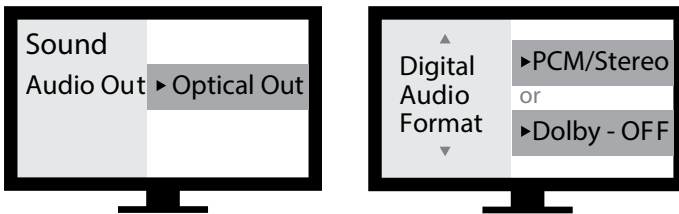

If you're having trouble finding these settings, you can scan the QR code correlating to your TV's brand OR visit [avantree.com/quartet/tv-audio-settings](http://avantree.com/quartet/tv-audio-settings) for a more detailed guide.



LG



SONY



SAMSUNG

NETFLIX /  
AMAZON PRIME

**NOTE 1:** Smart TVs automatically reset their settings after system updates. After an update, make sure your audio output / input format is set to "PCM" and NOT "AUTO" or "Dolby."

**NOTE 2:** When using Netflix or Amazon Prime, you may need to start the movie / show before changing the audio settings to "PCM."

## Charging the Headphones

Charge the headphones using the provided USB C 4 in 1 charging cable and a 5V/500mA-2A rated USB adapter (your phone charger or similar should work).

A solid red light indicates that charging is in progress; once the light turns off, your headphones are fully charged. It takes about 3 hours for the headphones to fully charge.

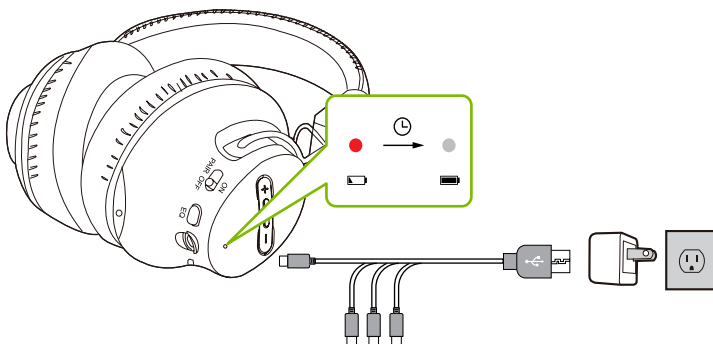

**NOTE:** We recommend using a USB adapter rated 1A-2A to charge the headphones, especially when charging four headphones simultaneously. Charging with a 500mA adapter may result in longer charging times when charging multiple headphones at once.

# Advanced Features

## Listening with a Soundbar

The Quartet's pass-through function allows you to listen through both the headphones and an external soundbar / stereo AVR simultaneously.

### STEP 1

Set up the transmitter and connect it to your TV

### STEP 2

Plug an additional optical, 3.5mm AUX, or RCA audio cable into the correlating audio port in the transmitter's **"BYPASS / SPEAKER"** section.

### STEP 3

Plug the other end into your external sound system, then you're good to go.

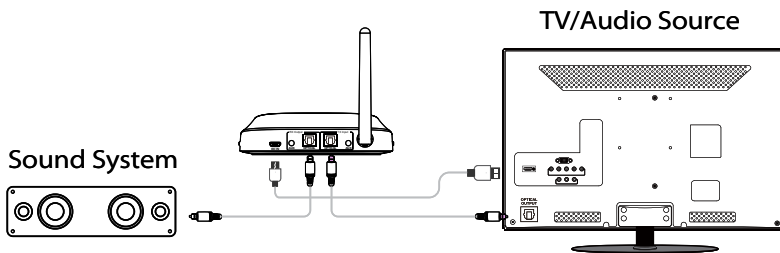

*NOTE: Bypass only works with the same type of input / output, i.e. if you connect to your TV via OPT, you'll need to connect to your speaker via OPT as well.*

## Adding More Headphones

You can add up to 100 Quartet-Extra headphones to your setup while maintaining low latency. Please note that ONLY Quartet-Extra / Duet-Extra headphones are compatible due to private protocol connections.

### STEP 1

On your transmitter, press & hold the “PAIR” button for 2 seconds. The “Link” LED indicator will flash white.

### STEP 2

Turn on your pair of Quartet-Extra headphones, then slide and hold the power switch to the “PAIR” position until the LED indicator flashes blue rapidly.

### STEP 3

Hold them close together and wait. Once connected, the headphones' connection LED indicator will turn solid blue.

Repeat these steps to add up to 100 headphones to your setup.

To purchase Quartet Extra headphones, scan the QR code below.





# Specifications

## Transmitter

Technology	2.4GHz
Frequency Response (Hz)	20Hz-20KHz
Operating range	Up to 100ft / 30m
Power supply	5V/1-2A
Power port	USB C

## Headphones

Technology	2.4GHz
Battery life	Up to 20 hours
Time to fully charge	3 hours
Distortion	0.5%
Signal to noise ratio	85dB
Headphones net weight	200g
Power supply	5V/1-2A
Power port	USB C

## FAQ

Below are some of the most common questions people have during setup.

### **Can I have audio through my TV's speakers and wireless headphones at the same time?**

This completely depends on whether or not your TV supports the ability to output audio to 2 sources simultaneously. You can try a few different methods to test if your TV is capable of this or not – refer to [avantree.com/quartet/sound](http://avantree.com/quartet/sound) for more details.

### **Why don't I get sound when watching Netflix / Prime Video?**

You may need to change your TV's audio settings an additional time when watching Netflix / Prime Video. This can be due to the movie being in Dolby Digital Surround Sound format, or because you're watching with a separate streaming device / cable box.

While Netflix / Prime Video is open, go into your TV's audio settings and make sure that the audio output is set to "PCM / STEREO" and that "DOLBY" is turned OFF.

### **Why am I getting Wi-Fi router interference?**

It's best to keep your transmitter at least 3ft / 1m away from Wi-Fi routers in order to avoid interference.

For answers to questions like these, you can visit [avantree.com/support/quartet](http://avantree.com/support/quartet) for a full FAQ list, or you can contact us directly for additional assistance.

## Contact Us



**Support Tickets** [avantree.com/submit-a-ticket](https://avantree.com/submit-a-ticket)

---



**Support Email** [support@avantree.com](mailto:support@avantree.com)

---



### Support Numbers

US	+1 800 232 2078	9am-6pm PST	Mon-Fri
CA	+1 800 232 2078	9am-6pm PST	Mon-Fri
UK	+44 208 068 2023	9am-6pm GMT	Mon-Sat
DE	+49 322 2109 7297	11am-9pm CET	Mon-Sat
FR	+33 17 634 0312	11am-9pm CET	Mon-Sat
IT	+39 069 4803 330	9am-6pm CET	Mon-Sat
ES	+34 93 1786 261	9am-6pm CET	Mon-Sat
AU	+61 2 8310 9897	11am-7pm AEST	Mon-Fri

---



**FAQ** [avantree.com/support/Quartet](https://avantree.com/support/Quartet)

---



**Video Guide** [avantree.com/Quartet/video](https://avantree.com/Quartet/video)

---



**Product Registration** See QR code on the product tag.

Manufacturer:  
Avantronics Limited  
Luohu District, Shenzhen 518000 China  
+ 86 755 8228 5022 support@avantree.com

US Importer:  
Avantree Corporation  
San Jose, California 95119 USA  
+1 800 232 2078 support@avantree.com

UK Importer:  
Avantree Limited  
Watford, WD180 0HQ UK  
+44 20 8068 2023 support@avantree.com



Servicer in Europe:  
Gizmex GmbH,  
Sternstr. 67, 40479 Dusseldorf, Germany  
+49 322 2109 7297 support@avantree.com



Model No.: WSHT-5049  
Dispose of the packaging and this product in accordance with the latest provisions.  
Z-PKQG-WSHT-5049-V7